

# Top 10 Reasons to Move from AutoCAD® to AutoCAD® Mechanical 2009

## Power Tools for Mechanical Design

To compete and win in today's global marketplace, drafters and designers need to create and revise mechanical drawings faster than ever before.

AutoCAD® Mechanical software, a purpose-built design and drafting application, offers significant productivity gains over basic AutoCAD® software by automating common tasks and simplifying complex mechanical design work. As a result, you gain a competitive edge by saving countless hours of design and rework, so you can spend time innovating, rather than managing workflow issues.

Discover why so many designers and drafters are switching to AutoCAD Mechanical.

## 1. 700,000 Standard Parts and Features

When you are dealing with machinery that contains hundreds or thousands of parts, it could take days, or even weeks, to draw them from scratch. AutoCAD® Mechanical software changes that by providing a comprehensive set of parts and features that you can select for your designs. When you insert content, AutoCAD Mechanical intelligently cleans up the surrounding geometry so you don't have to edit it manually. Examples include the following:

### Manufactured Parts

- Screws, Nuts, Washers
- Pins, Rivets, Bushings
- Plugs, Lubricators, Sealing Rings
- Bearing and Shaft Components
- Structural Steel Shapes
- Through, Tapped, Blind, and Oblong Holes
- Undercuts, Keyways, and Thread Ends

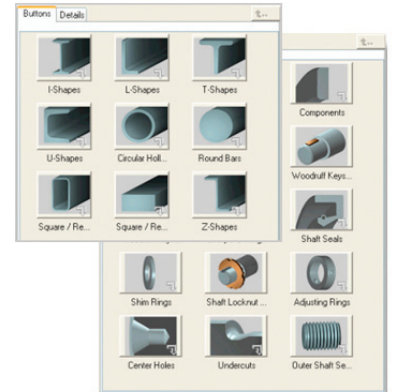

## 2. Extended Draw Toolbar for Manufacturing

AutoCAD Mechanical provides additional options over basic AutoCAD® software for drawing creation, including:

- More than 30 options for rectangle, arc, and circle creation
- Nearly automatic centerline creation and updating
- Specialty lines for breakout views and section lines
- A full suite of construction lines for aligning drafting views
- Manufacturing-focused hatching patterns and sizes

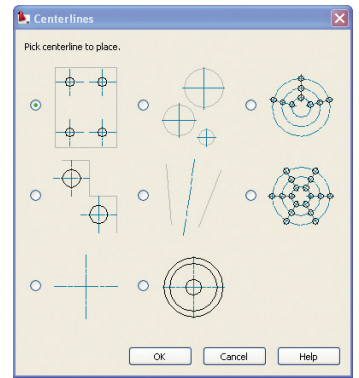

## 3. Powerful and Smart Dimensions

With the streamlined tools in AutoCAD Mechanical, you can create dimensions using abbreviated dialog boxes that conveniently control and expand only the relevant variables for manufacturing. With automatic dimensioning, you can create multiple dimensions with minimal input, resulting in instant groups of ordinate, parallel, or symmetric items that are appropriately spaced. Smart dimensioning tools force overlapping dimensions to automatically space themselves appropriately while integrating tolerance and fit list information into the design. Dimension input can even drive and change design geometry to fit certain sizes.

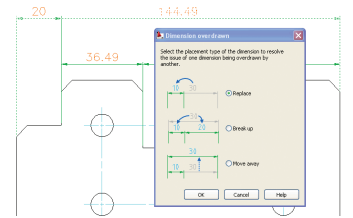

## 4. Reusable Detailing Tools

Built to save you time, AutoCAD Mechanical has a specific tool for almost every aspect of the mechanical drafting process. Many of these drafting tools have the intelligence that helps users easily re-edit features without having to remove and re-create the original feature. For example, a chamfer or fillet can be easily resized through the original dialog box parameters by simply double-clicking the chamfer or fillet. The list of tools includes, but is not limited to the following:

- Detail Views—Easily create linked views at different scales
- Hole Charts—Automatically update charts for the shop floor
- Title and Revision Blocks—English and metric versions available

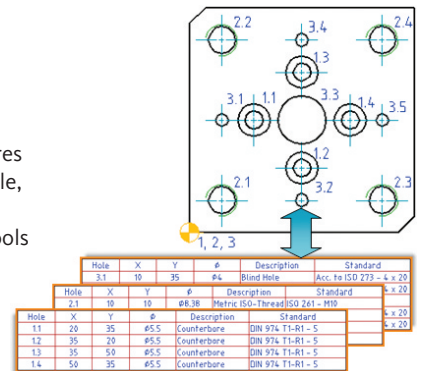

## 5. Support for International Drafting Standards

Multiply your productivity with tools that help you and your team deliver consistent, standards-based design documentation. AutoCAD Mechanical software supports ANSI, BSI, CSN, DIN, GB, ISO, JIS, and GOST drafting environments. Adhering to a standard environment improves team communication and helps drive consistent production results. AutoCAD Mechanical also includes drafting tools for creating standards-based surface texture symbols, geometric dimensioning and tolerances, datum identifiers and targets, notes, taper and slope symbols, and weld symbols.

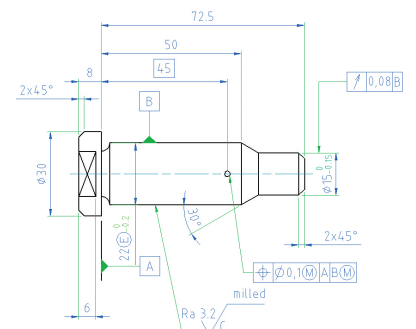

## 6. Associative Balloons and Bill of Materials (BOMs)

Create automated and associative part lists and BOMs that are specifically developed for manufacturing and that automatically update as the design changes. AutoCAD Mechanical software includes support for multiple parts lists for each drawing, collapsible assemblies, automatic recognition of standard parts, and customizable options so that features can be revised to match current company practices. Change a design once and updates ripple through the entire drawing to keep everyone on schedule, reducing costly stops in production from incorrect part counting, identification, and ordering. Export or link BOM data to manufacturing resource planning (MRP), enterprise resource planning (ERP), or data management systems such as Autodesk® Productstream® software.

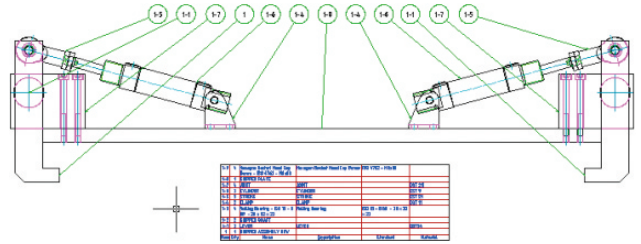

## 7. Layer Management

The intelligent layer management system in AutoCAD Mechanical automatically places items on the correct layer, color, and linetype as you create your drawing. And, the software can be easily customized based on your company requirements.

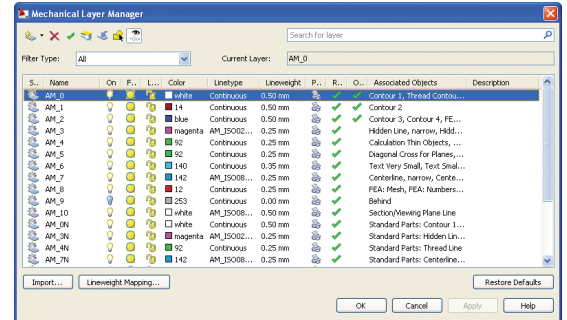

## 8. Hidden Lines

Ramp up your productivity by defining simple foreground and background selections that automatically redraw geometry to show hidden or dashed lines of parts that are obstructed by other parts in your design. The hidden lines automatically update when changes occur, virtually eliminating time-consuming manual redrawing of geometry due to iterative changes. For the first time in 2D, identical parts can have different geometrical appearances when in hide situations, but AutoCAD Mechanical recognizes that they are still identical parts if you need to change the design or get an accurate count for the parts list. This means you'll spend less time and effort updating your 2D designs.

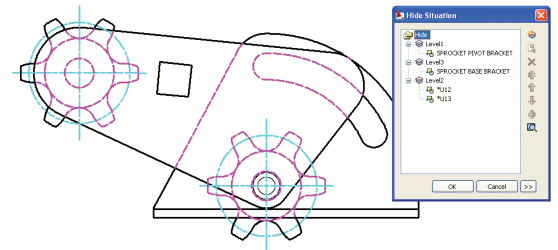

## 9. Machinery Generators and Calculators

If you are building mechanisms from paper catalogs and manual calculations, the comprehensive machinery generator and calculator tools can be a huge time-saver. Built into the application environment, these tools are extremely helpful when making small, iterative changes to improve your design. They not only create parts according to your specifications, but they also create all the reports and calculations you need to analyze the design. AutoCAD Mechanical includes shaft, spring, belt, chain, and cam generators.

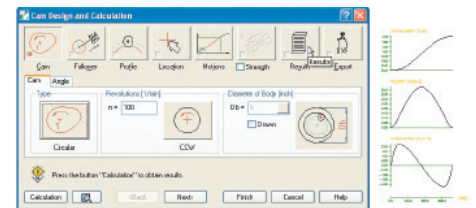

## 10. Data Exchange Between CAD Systems

Use AutoCAD Mechanical to detail and document native Autodesk® Inventor™ models. Incorporate design revisions quickly and easily through the associative link—the software automatically notifies you of changes to the Inventor file and regenerates the 2D drawing, including any changes. AutoCAD Mechanical also includes the industry-standard IGES (Initial Graphics Exchange Specification) and STEP (Standard for the Exchange of Product Data) formats for exchanging data between dissimilar CAD systems.

### Now Is the Time

Want to increase your productivity by up to 65 percent? Then now is the time to move to AutoCAD Mechanical.

\*The AutoCAD Mechanical Productivity Study compares the time required to complete 10 tasks in both basic AutoCAD and AutoCAD Mechanical. The conclusion: switching to AutoCAD Mechanical can help increase your productivity by as much as 65 percent.

To learn more, visit [www.autodesk.com/autocadmechanical-productivity](http://www.autodesk.com/autocadmechanical-productivity).

For more information about AutoCAD Mechanical, go to

[www.autodesk.com/autocadmechanical](http://www.autodesk.com/autocadmechanical).

To locate the reseller nearest you, visit [www.autodesk.com/reseller](http://www.autodesk.com/reseller).

